

# VTSDIR

velleman®

## INFRA-RED SMD & BGA REWORK STATION



**Main station front panel**

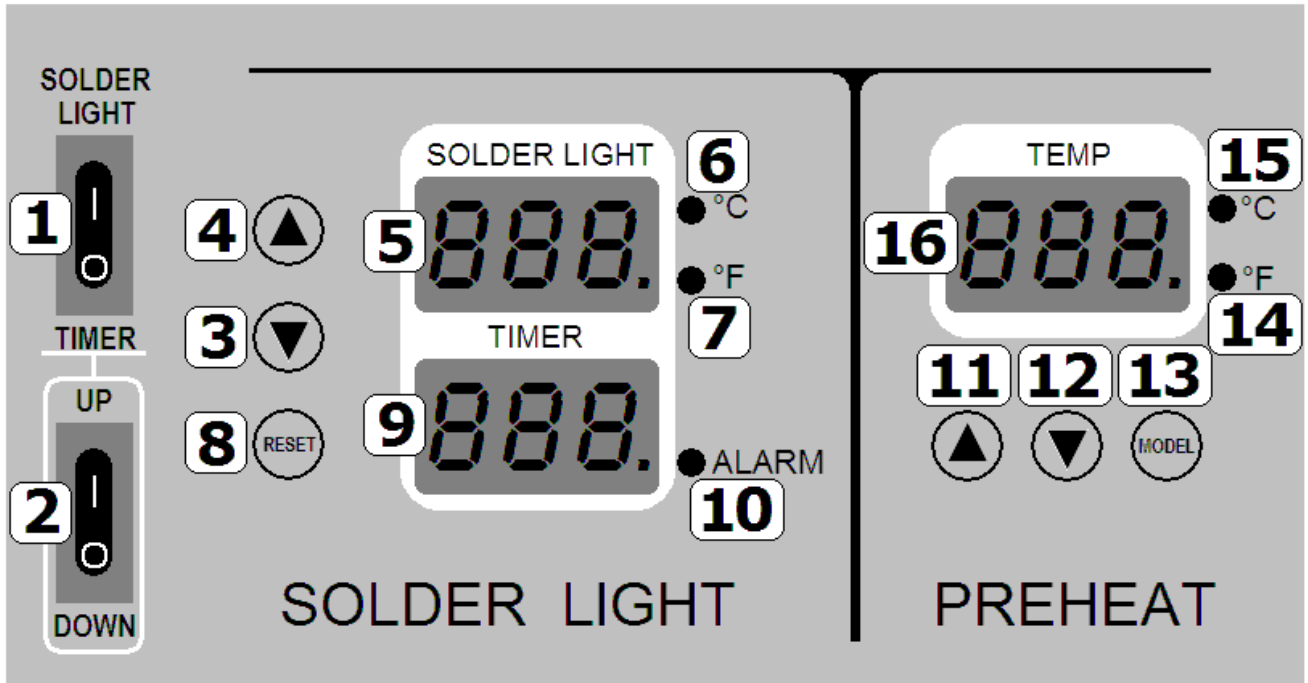

**Main station rear panel**

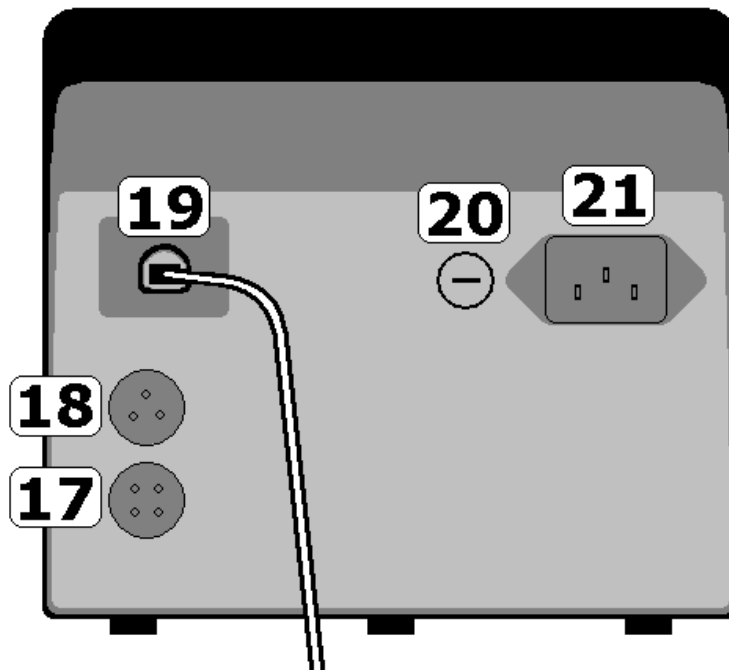

# User manual

## 1. Introduction

To all residents of the European Union

### Important environmental information about this product



This symbol on the device or the package indicates that disposal of the device after its lifecycle could harm the environment. Do not dispose of the unit (or batteries) as unsorted municipal waste; it should be taken to a specialized company for recycling. This device should be returned to your distributor or to a local recycling service. Respect the local environmental rules.

**■ If in doubt, contact your local waste disposal authorities.**

Thank you for buying the **VTSDIR**! Please read the manual thoroughly before bringing this device into service. If the device was damaged in transit, do not install or use it and contact your dealer.

This appliance is specially designed for SMD/BGA rework and also very convenient for re-balling smaller BGA components.

Please read this manual carefully to maximize the advantages of using your new SMD/BGA rework system and keep this manual readily accessible for reference.

**For more info concerning this product and the latest version of this user manual, please visit our website [www.velleman.eu](http://www.velleman.eu).**

## 2. Safety Instructions



**WARNING and CAUTION**



**ELECTRICAL SHOCK**

*Warning and Caution are positioned at critical points in the manual to draw the user's attention to significant safety concerns. Be sure to comply with the following warnings and cautions for your safety.*

1. Ensure the voltage rating of the unit and your mains power supply is identical prior to use.
2. Check carefully of any damage during transportation.
3. Put the products on a safe and stable working table. Table surface should be consisted of fire and heat resistant material due to the unit can reach very high temperature and potentially dangerous.
4. During the operation, the heater is extremely hot, and will cause serious burns if contacted exposed skin. Use gloves and/or any heat resistant tools to pick up the PCB assembly to eliminate the possibility of burns.
5. Do not use the product near combustible gases or flammable materials.
6. Turn the power switch OFF and allow the heater to cool before checking or replacing heater and other parts, or prior to storing the unit.
7. Keep the appliance cleaning especially the quartz heater. This may be used with a damp cloth using small amount of liquid detergent. Never submerge the unit in liquid or allow any liquid to enter the station. Never use any solvent to clean the case.
8. Quartz heater is fragile, be slightly moving the station if necessary.
9. This unit is designed for SMD rework, BGA re-balling and pre-heating PCB assembly and should not be used for any other purpose without first consulting the manufacturer or its authorized agent.
10. Keep the unit out of the reach of children. Young Children should be supervised to ensure that they do not play with the appliance.

### To prevent electrical shock, be sure to take the following precautions:

1. Make sure the unit is grounded. Always connect power to a grounded receptacle.
2. Do not pressure the AC power cord. Be sure the work area is well ventilated.
3. Do not bump, hit, pour water/liquids or otherwise subject the heating surface to physical shock. This may damage the quartz heater.
4. To isolate the equipment from the mains before commencing repairs or making any maintenance to avoid electric shock. This may result in Death or serious injury.
5. Do not expose the unit to moisture nor use the unit with wet hands.
6. Turn the power switch off and remove the AC power cord by pulling the plug (not the cable) when the unit will remain unused for a longer period of time.
7. Do not modify the unit.





### Warnings

- **This system is designed to be used for soldering/desoldering SMDs** and should not be used for any other purpose without consulting manufacturer or its agents.
- **The IR hand tool is designed for intermitted use only.** It is not designed to be used continuously without being allowed to cool. It should be used a maximum of 5 minutes before cooling. After using the IR hand tool, ensure that it is placed back in its cooling stand to cool down between rework operations. Also, do not switch the IR Hand tool on while it is in the cooling stand. **Fail to comply with these instructions may result in damage to the IR hand tool or the cooling stand.**
- **Do not aim the IR hand tool at your eyes.** Do not allow the IR spot from the IR hand tool (either directly or via mirror) to shine into the eyes as serious eye damage may occur.

- **The system can produce a lot of heat.** Do not allow the IR spot from the IR hand tool or IR from the PCB pre-heater, to contact exposed skin as burning may occur. To eliminate the possibility of burns, allow time for the equipment to cool before commencing maintenance.
- **Death or serious injury may result from electric shock.** It is therefore essential to isolate the equipment from the mains before commencing repairs.
- **Do not allow the spillage of any liquid to fall on the quartz emitter (pre-heater)** as damage may result. Due to the use of glass optical components, the IR hand tool should be handled with reasonable care.
- Keep this device away from children and unauthorized users.

### 3. General Guidelines

Refer to the **Velleman® Service and Quality Warranty** on the last pages of this manual.

	<b>Indoor use only.</b> Keep this device away from rain, moisture, splashing and dripping liquids.
	Keep this device away from dust and extreme heat.
	Protect this device from shocks and abuse. Avoid brute force when operating the device.

- Familiarise yourself with the functions of the device before actually using it.
- All modifications of the device are forbidden for safety reasons. Damage caused by user modifications to the device is not covered by the warranty.
- Only use the device for its intended purpose. Using the device in an unauthorised way will void the warranty.
- Damage caused by disregard of certain guidelines in this manual is not covered by the warranty and the dealer will not accept responsibility for any ensuing defects or problems.

### 4. Overview

Refer to the illustrations on page 2 of this manual.

#### Main station – solderlight section

1. SOLDERLIGHT/Timer alternate switch: **I** = Solderlight temperature controlled, **O** = time counting.
2. Time counting switch: **I** = time counting up, **O** = time counting down
3. “▼” key: Time counting / Actual temperature decrease
4. “▲” key: Time counting / Actual temperature increase
5. IR Temperature display / IR hand tool power
6. Celsius (°C): IR Temperature in degrees Celsius indicator
7. Fahrenheit (°F): IR Temperature in degrees Fahrenheit indicator
8. “RESET”: Offset forward counting for “TIMER”
9. “TIMER” display: Time counting display / Process timer
10. “ALARM”: alarm indicator

#### Main station – Preheat section

11. “▲” key: Temperature pre-heater up (increase)
12. “▼” key: Temperature pre-heater down (decrease)
13. “MODEL”: Actual temperature offset pre-heater
14. Fahrenheit (°F): Pre-heater temperature indicating light
15. Celsius (°C): Pre-heater temperature in degrees Celsius indicator
16. Preheat temperature setting display (3 segments)

#### Main station - rear panel

17. Solderlight Foot switch socket (4 pin)
18. DC12V Cooling fan socket (3 pin)
19. Output to PREHEATER
20. Fuse Holder
21. AC power inlet (Mains inlet)

### 5. Working Temperature

The most common soldering alloys used in the electronics industry consist of 60% tin and 40% lead. The operating temperature of this type of solder is detailed below and can vary from manufacturer to manufacturer. However, to meet RoHS requirements, these solders are no longer allowed and are replaced by lead-free solders that require a working temperature which is ±30°C (54°F) higher.

	leaded solder	lead-free
Melting point	215°C (419°F)	220°C (428°F)
Normal Operation	270-320°C (518-608°F)	300-360°C (572-680°F)
Production Line Operation	320-380°C (608-716°F)	360-410°C (680-770°F)

## 6. Setup

Refer to the illustrations on page 2 of this manual.

**Note:** never unplug any connection during operation.

- The equipment must be sited on a firm surface at least 1.2M x 0.75M and at a height to suit the operator. The location should be chosen to suit the flow of work.
- Plug the solder light plug into the socket on the front of the main station.
- Plug the solder light fan into the cooling fan socket [18] and place the solder light in the holder.
- Plug the footswitch into the foot switch socket [17].
- The quartz heaters are secured against shocks with a metal bar and plastic tubes. Remove these and mount the metal grid in place (refer to Appendix 1).
- Mount the PCB holder (refer to Appendix 2).
- Plug the power cord into the AC power inlet [21].

## 7. Operation

- The principle of operation of IR rework system is that whilst being heated from above and below, a single SMD is subjected to similar temperature/time profile during rework as it experiences during reflow in the original production process.

**Note:** wait about 5 minutes for the system to warm up after changing a setting.

### IR hand tool operation:

- Set the "SOLDERLIGH/TIMER" switch [1] to the SOLDERLIGHT position (I).
- Set the IR Lamp temperature using the "▼" [3] and "▲" [4] keys. Press and hold ±2s to increase setting speed. Read the temperature on the display [5].

**Note:** the temperature depends on the type of work (normally about 240°C)

### Standard operation

- Press on the footswitch to start the IR heating; release to stop IR heating.

### Timer-up operation

- Set the "SOLDERLIGH/TIMER" switch [1] to the TIMER position (O).
- Set the "Time counting" switch [2] to the UP position (I).
- Press on the footswitch to start IR heating; release to stop IR heating. The timer display [9] will count the number of seconds that the IR heating was on.

### Timer-down operation

- Set the "SOLDERLIGH/TIMER" switch [1] to the TIMER position (O).
- Set the "Time counting" switch [2] to the DOWN position (O).
- Set the timer using the "▼" [3] and "▲" [4] keys. Press and hold ±2s to increase setting speed. Read the time (in seconds) on the display [9].
- Press on the footswitch to start IR heating; release to stop IR heating. The timer display will count down the number of seconds that the IR heating was on. When 000 is reached, a warning signal sounds.

### Notes:

- Press the reset switch [8] to return the display to 000.
- To determine the reflow time of a new component, first use the timer up operation until it reflows, than use the timer value for timer-down operation.

### Pre-heater operation:

- Set the pre-heater temperature using the "▼" [12] and "▲" [11] keys. Press and hold ±2s to increase setting speed. Read the temperature on the display [16].

**Note:** the temperature depends on the type of work (normally about 220°C)

### Actual temperature compensation value

- Press on the MODEL button [13] until the display shows "---" (±4s). The temperature compensation is shown for ±2s.
- To change the value, press the MODEL button [13] again. The value on the display starts to flash and can be set using the "▼" [12] and "▲" [11] keys.

**Note:** when the display shows "00" or "-00" the compensation is "+10".

E.g. When the temperature is set at 200°C and the measured temperature is only 190°C, then the value must be set to "00" or "-00". If the measured value is 180°C, than the compensation value must be set to "+10" (-20 + 10 = 10).

### General operation:

**CAUTION:** to avoid burns, do not touch the heater or PCB directly, use clips or tweezers to pick up or align components.

**CAUTION:** do not allow water/liquids/solvents to touch the heater surface to avoid temperature drop cracks while the unit is still hot. Such cracks can lead to electrical shorts or failure of the heater.

**CAUTION:** Do not touch the PCB holder to avoid burning your skin during preheat!

## Preparation

The procedure for preparing to rework SMT/BGA components is as follows:

- Switch on and warm up.
- Set 'control settings' required for PCB/component
- Sort tools and fluxes required.

The following tools are required for use in soldering/desoldering operations:

- SMT Tweezers, fine tipped
- Flux dispenser bottle
- Low solids and gel/paste flux

## Temperature profile

In normal operation the component is first put through a preheat stage, followed by a reflow stage. The system is designed for rework single/double side and mixed technology PCB. The top heat is derived from a 150W short wave IR lamp focused through a reflective chamber system. The bottom heater delivers a maximum of 650W medium wave IR.

In normal use, approximately 25% of the energy is provided by the top heater, and 75% of the energy is provided by the back heater (pre-heater). Figure below shows how the energy is applied to a component.

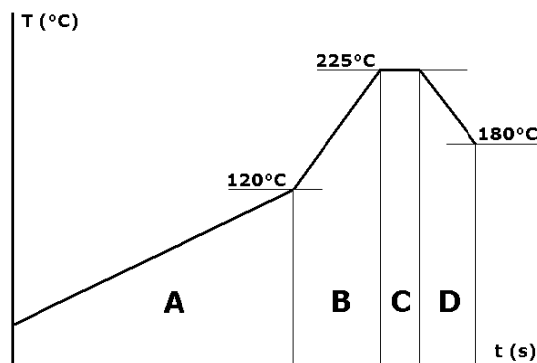

## Soldering

- **PREPARATION:** place the PCB in the PCB holder, positioning the component site to be reworked over the centre of the PCB pre-heater. For BGAs, apply a very small amount of gel flux (approx. 0.1 - 0.15mm) thickness). Place and align component. **Note** – depending on the application, you may be required to apply solder paste to the PCB before placing component.
  - **[A] PREHEAT** the fluxed component/PCB to approximately 120°C (as measured by the IR sensor).
  - **[B] REFLOW:** use the IR hand tool (operated by pressing the footswitch) for the reflow phase to heat the component up to reflow temperature (200-225°C). It is not so easy to measure temperature during the reflow phase so therefore we use the timer on the IR 810 controller to limit the reflow phase time (normally 30-45 seconds for a small PCB).
  - **[C] SOAK** for a short period soak (about 10 seconds) the component allowing the joints to fully bond.
  - **[D] COOL:** allow the component to cool to below 180°C before moving the PCB.

## Desoldering

- **PREPARATION:** place PCB in the PCB holder, positioning the component site to be reworked over the centre of the PCB pre-heater. Apply a very small amount of flux under/around the component.
  - **[A] PREHEAT** the fluxed component/PCB to approximately 120°C (as measured by the IR sensor).
  - **[B] REFLOW:** use the IR hand tool (operated by pressing the footswitch) for the reflow phase to heat the component up to reflow temperature (200-225°C). It is not so easy to measure temperature during the reflow phase so therefore we use the timer on the IR810 controller to limit the reflow phase time (normally 30-45 seconds for a small PCB).
  - **[C] SOAK** for a short period soak (about 10 seconds) the component allowing the joints to fully bond.
  - **[D] COOL** – allow the component to cool to below 180°C before moving the PCB.

## Aftercare

- Clean flux residue off PCB if necessary
- Check solder joints
- Test

## 8. Q&A

- What Top Heat setting should you use?  
Between 220 and 380°C. Normal setting is 240°C.
- What's the working distance of the IR Hand tool and how do I move it for rework?  
Approximately 5~10 mm when reworking and move up to 30mm when removing components.  
Move the hand tool in a scanning motion to heat leads, taking about one second for each scan of the component.
- What pre-heater setting should I use?  
Between 200 and 290°C. Normal setting is 240°C.

- How long do I preheat the PCB?  
 Always preheat the PCB (up to 120°C or between 45 – 90 seconds) to allow the heat to conduct through to the component before introducing the top heat. With the 700W pre-heater the top of a small PCB will reach 120°C in approximately 45 – 90 seconds. Larger PCBs will take longer to pre-heat. To check the PCB/component temperature, use the hand-held IR temperature sensor to 'look' down at the PCB/component from about 60mm away and at about 45° angle.
- How long does it take to reach reflow temperature?  
 After preheating the PCB up to 120°C, it should normally take about 30 – 45 seconds of heating with the IR hand tool to reach reflow temperature (200-220°C). It is not so easy to measure temperature during the reflow phase so therefore we use the electronic process timer to warn us when the reflow phase time is over.

**9. Technical specifications**

mains power		230VAC
IR solderlight	power	150W
	temperature range	45 ~ 350°C
	time setting	0 ~ 900s
pre-heater	power	650W
	temperature range	100 ~ 350°C
dimensions	controller	170 x 158 x 137 mm
	pre-heater	280 x 90 x 260 mm
weight		±7kg

**Use this device with original accessories only. Velleman nv cannot be held responsible in the event of damage or injury resulted from (incorrect) use of this device.**

**The information in this manual is subject to change without prior notice.**

**© COPYRIGHT NOTICE**

**The copyright to this manual is owned by Velleman nv.** All worldwide rights reserved.

No part of this manual or may be copied, reproduced, translated or reduced to any electronic medium or otherwise without the prior written consent of the copyright holder.

# Appendix 1

Remove screws [X], remove metal bar [Y] and remove plastic tubes [Z].

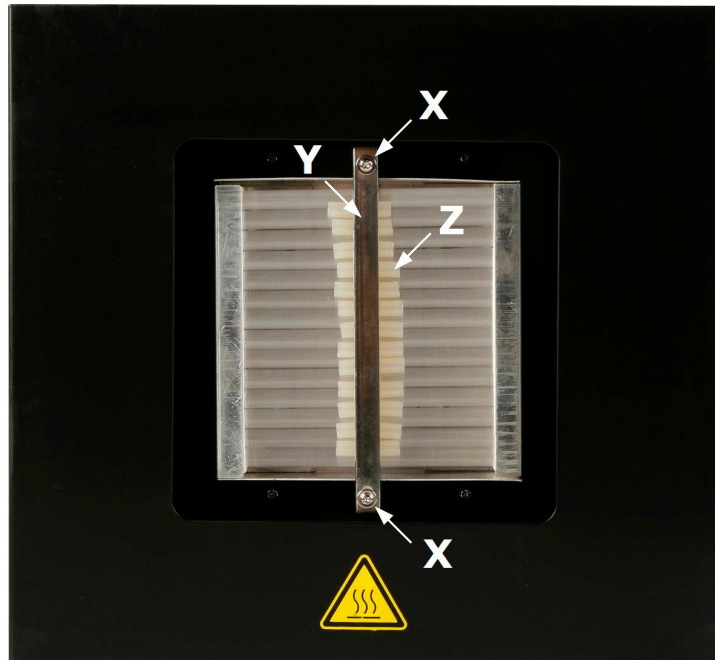



Place the metal grid and secure it with the two screws [X].

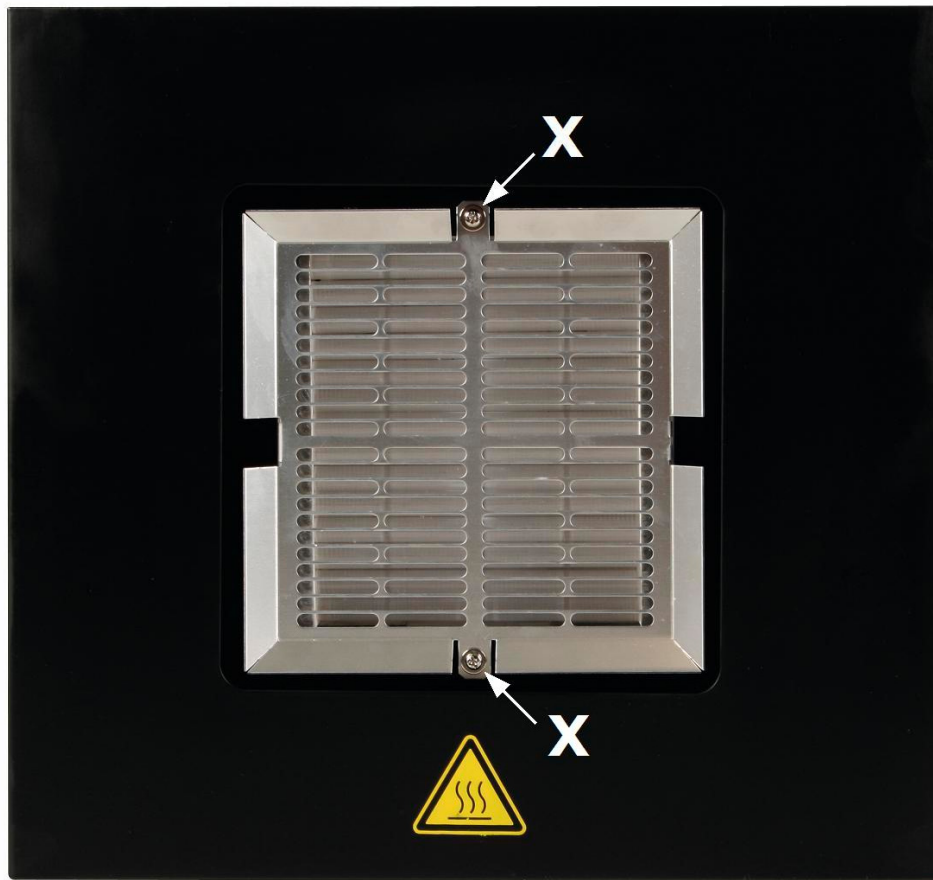

# Appendix 2

**1**

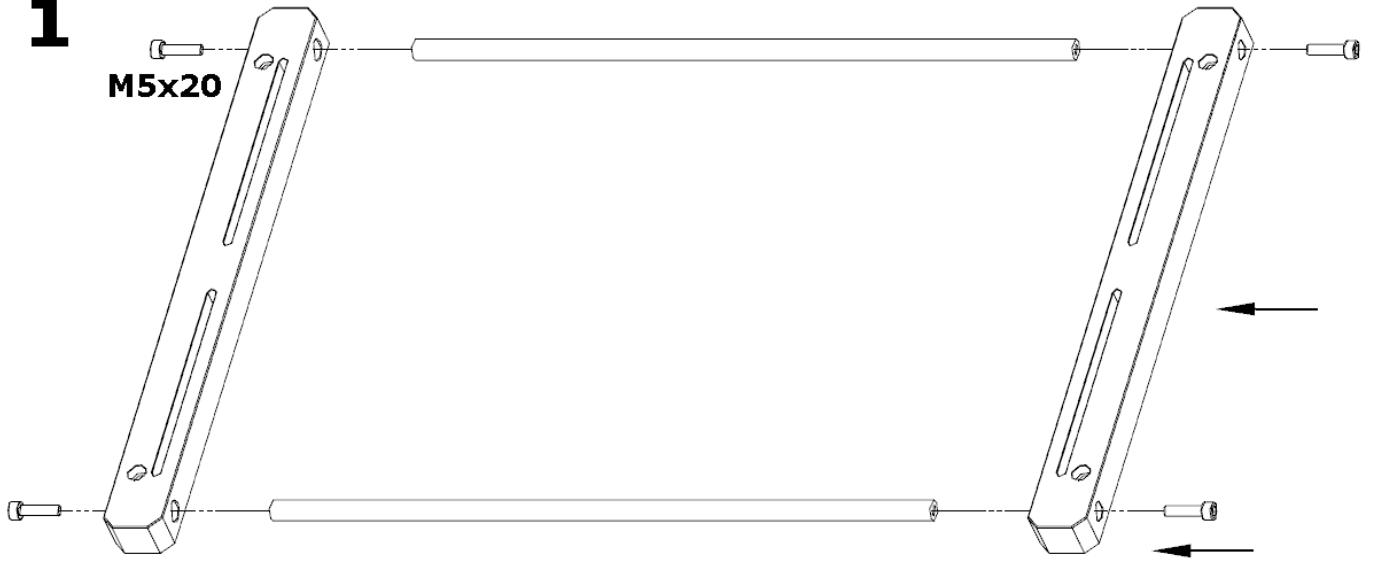

**2**

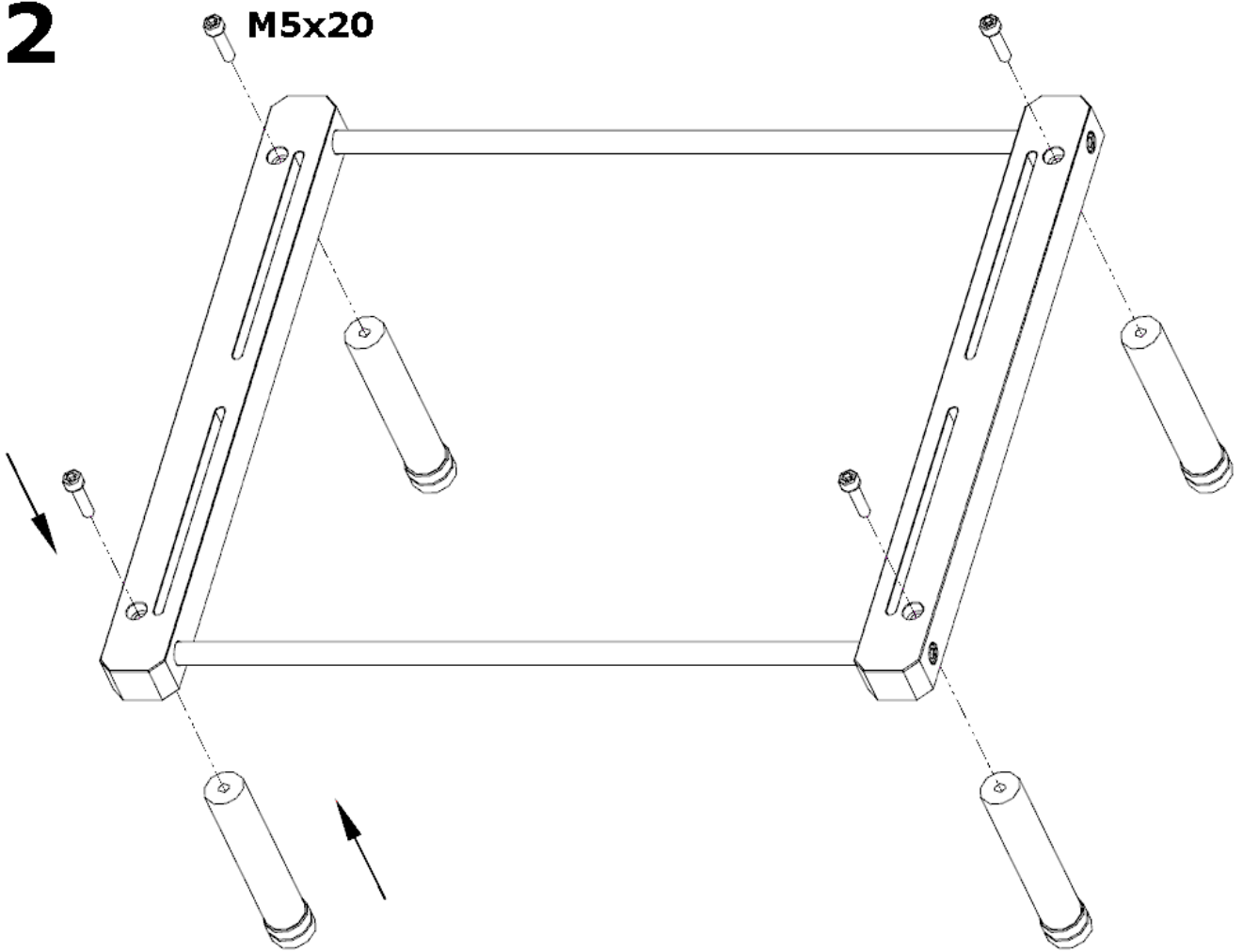

**3**

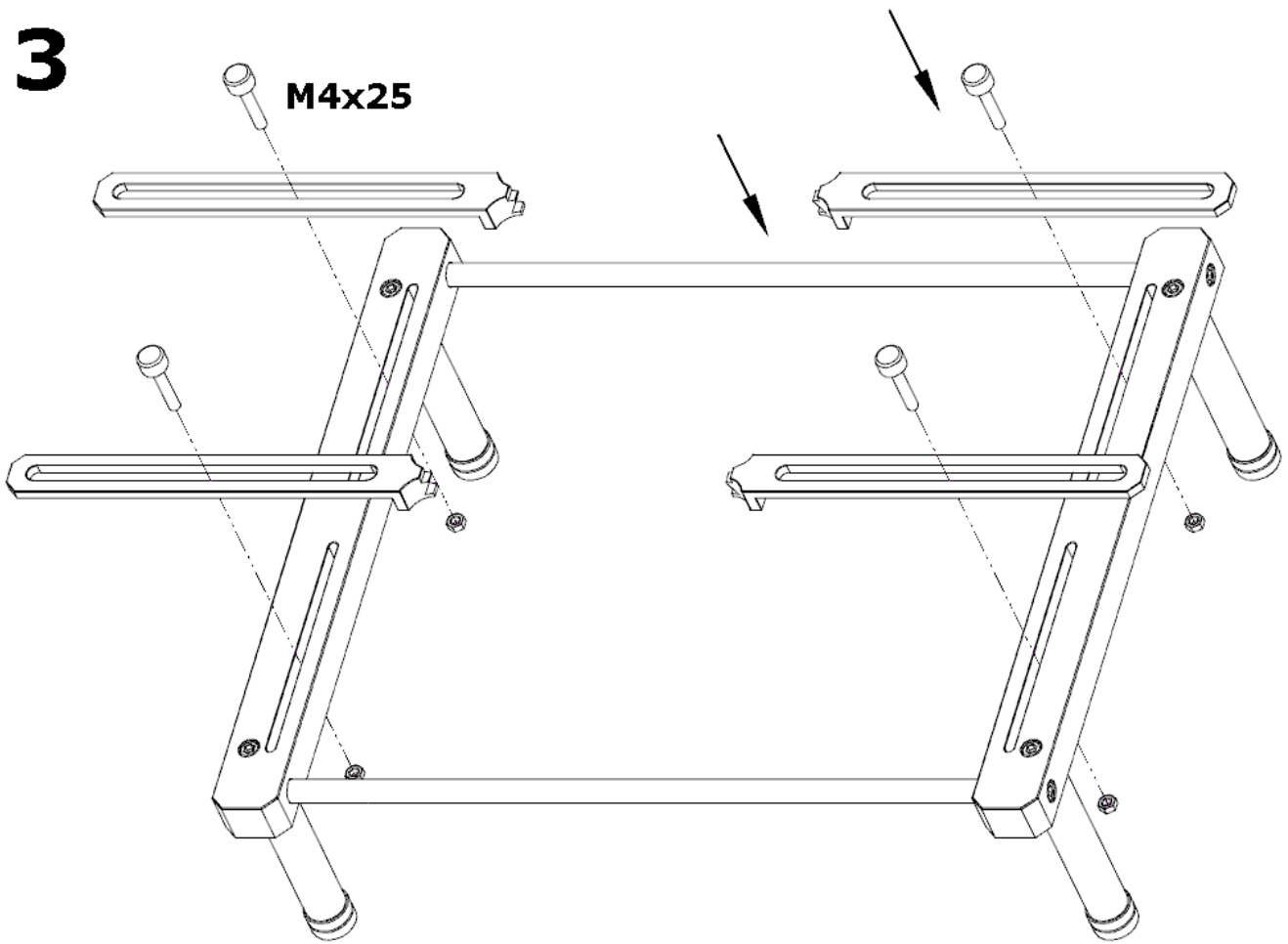

**4**

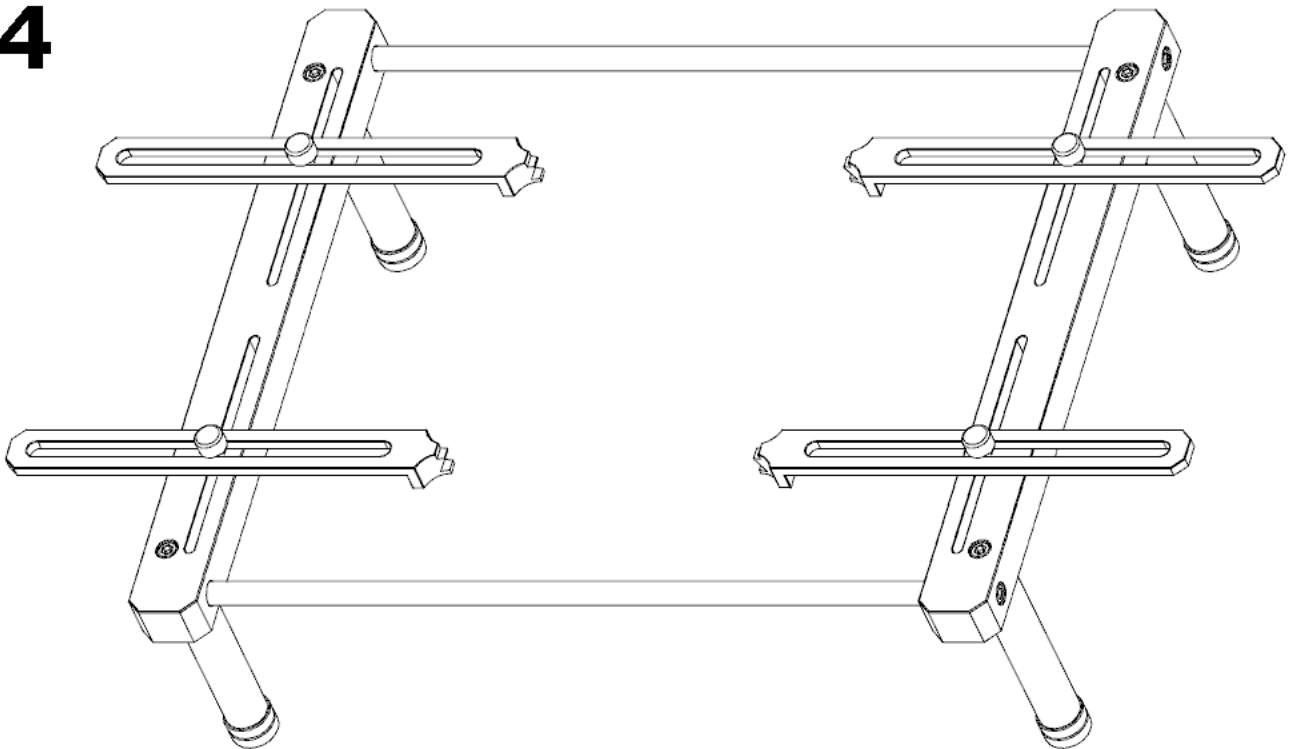



### **Velleman® Service and Quality Warranty**

Velleman® has over 35 years of experience in the electronics world and distributes its products in more than 85 countries. All our products fulfil strict quality requirements and legal stipulations in the EU. In order to ensure the quality, our products regularly go through an extra quality check, both by an internal quality department and by specialized external organisations. If, all precautionary measures notwithstanding, problems should occur, please make appeal to our warranty (see guarantee conditions).

#### **General Warranty Conditions Concerning Consumer Products (for EU):**

- All consumer products are subject to a 24-month warranty on production flaws and defective material as from the original date of purchase.
- Velleman® can decide to replace an article with an equivalent article, or to refund the retail value totally or partially when the complaint is valid and a free repair or replacement of the article is impossible, or if the expenses are out of proportion.

You will be delivered a replacing article or a refund at the value of 100% of the purchase price in case of a flaw occurred in the first year after the date of purchase and delivery, or a replacing article at 50% of the purchase price or a refund at the value of 50% of the retail value in case of a flaw occurred in the second year after the date of purchase and delivery.

#### **• Not covered by warranty:**

- all direct or indirect damage caused after delivery to the article (e.g. by oxidation, shocks, falls, dust, dirt, humidity...), and by the article, as well as its contents (e.g. data loss), compensation for loss of profits;
- frequently replaced consumable goods, parts or accessories such as batteries, lamps, rubber parts, drive belts... (unlimited list);
- flaws resulting from fire, water damage, lightning, accident, natural disaster, etc. ...;
- flaws caused deliberately, negligently or resulting from improper handling, negligent maintenance, abusive use or use contrary to the manufacturer's instructions;
- damage caused by a commercial, professional or collective use of the article (the warranty validity will be reduced to six (6) months when the article is used professionally);
- damage resulting from an inappropriate packing and shipping of the article;
- all damage caused by modification, repair or alteration performed by a third party without written permission by Velleman®.

• Articles to be repaired must be delivered to your Velleman® dealer, solidly packed (preferably in the original packaging), and be completed with the original receipt of purchase and a clear flaw description.

• Hint: In order to save on cost and time, please reread the manual and check if the flaw is caused by obvious causes prior to presenting the article for repair. Note that returning a non-defective article can also involve handling costs.

• Repairs occurring after warranty expiration are subject to shipping costs.

• The above conditions are without prejudice to all commercial warranties.

**The above enumeration is subject to modification according to the article (see article's manual).**

---