

EN LOGIC LEVEL SHIFTER MODULE

WPI474

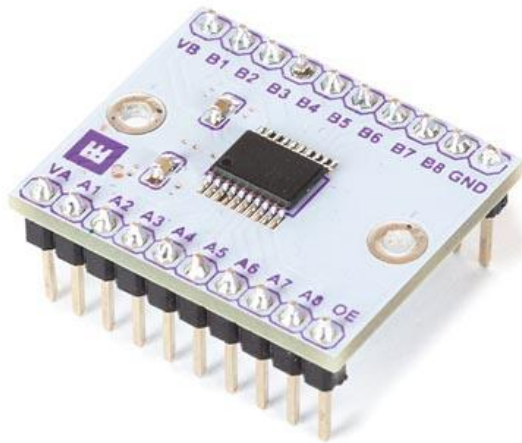

Introduction



To all residents of the European Union

Important environmental information about this product

This symbol on the device or the package indicates that disposal of the device after its lifecycle could harm the environment. Do not dispose of the unit (or batteries) as unsorted municipal waste; it should be taken to a specialized company for recycling. This device should be returned to your distributor or to a local recycling service. Respect the local environmental rules.

If in doubt, contact your local waste disposal authorities.

Thank you for choosing Whadda! Please read the manual thoroughly before bringing this device into service. If the device was damaged in transit, do not install or use it and contact your dealer.

Safety Instructions



Read and understand this manual and all safety signs before using this appliance.



For indoor use only.

- This device can be used by children aged from 8 years and above, and persons with reduced physical, sensory or mental capabilities or lack of experience and knowledge if they have been given supervision or instruction concerning the use of the device in a safe way and understand the hazards involved. Children shall not play with the device. Cleaning and user maintenance shall not be made by children without supervision.

General Guidelines

- Refer to the Velleman® Service and Quality Warranty on the last pages of this manual.
- All modifications of the device are forbidden for safety reasons. Damage caused by user modifications to the device is not covered by the warranty.
- Only use the device for its intended purpose. Using the device in an unauthorised way will void the warranty.
- Damage caused by disregard of certain guidelines in this manual is not covered by the warranty and the dealer will not accept responsibility for any ensuing defects or problems.
- Nor Velleman nv nor its dealers can be held responsible for any damage (extraordinary, incidental or indirect) – of any nature (financial, physical...) arising from the possession, use or failure of this product.
- Keep this manual for future reference.

What is Arduino®

Arduino® is an open-source prototyping platform based on easy-to-use hardware and software. Arduino® boards are able to read inputs – light-on sensor, a finger on a button or a Twitter message – and turn it into an output – activating of a motor, turning on an LED, publishing something online. You can tell your board what to do by sending a set of instructions to the microcontroller on the board. To do so, you use the Arduino programming language (based on Wiring) and the Arduino® software IDE (based on Processing). Additional shields/modules/components are required for reading a twitter message or publishing online. Surf to www.arduino.cc for more information

Product overview

The Whadda Logic Level Shifter module provides 8 logic conversion channels to enable microcontrollers, sensors and modules with different logic level voltages to communicate with each other. Each channel is fully bidirectional, and is compatible with both open-drain and push-pull logic drivers. The module can be used to convert 3.3 V to 5 V, 1.8-3.3 V and other common logic levels.

It is recommended to pull the Output Enable pin high with a pullup resistor to ensure the outputs are properly enabled. If the different logic level data lines need to be isolated, the Output Enable line can be pulled low. This will put all of the I/O channels in a high-impedance state.

Specifications

IC type: TI TXS0108E

Low-level voltage range: 1,4 – 3,6 V

High-level voltage range: 1,65 – 5,5 V

Dimensions (W x L x H): 22,4 x 26,7 x 12,5 mm

Wiring description

Pin	Name	Description
VA	Low voltage supply (1,4 – 3,6 V)	Voltage supply of low-level side, should always be lower than voltage on VB pin
A1	Low voltage I/O channel 1	Input-Output channel 1 of low-level side
A2	Low voltage I/O channel 2	Input-Output channel 2 of low-level side
A3	Low voltage I/O channel 3	Input-Output channel 3 of low-level side
A4	Low voltage I/O channel 4	Input-Output channel 4 of low-level side
A5	Low voltage I/O channel 5	Input-Output channel 5 of low-level side
A6	Low voltage I/O channel 6	Input-Output channel 6 of low-level side
A7	Low voltage I/O channel 7	Input-Output channel 7 of low-level side
A8	Low voltage I/O channel 8	Input-Output channel 8 of low-level side
OE	Output Enable	Disables the device when set low, which places all I/O channels in the high-impedance state.
VB	High voltage supply (1,65 – 5,5 V)	Voltage supply of high-level side, should always be higher than voltage on VA pin
B1	High voltage I/O channel 1	Input-Output channel 1 of high-level side
B2	High voltage I/O channel 2	Input-Output channel 2 of high-level side
B3	High voltage I/O channel 3	Input-Output channel 3 of high-level side
B4	High voltage I/O channel 4	Input-Output channel 4 of high-level side
B5	High voltage I/O channel 5	Input-Output channel 5 of high-level side
B6	High voltage I/O channel 6	Input-Output channel 6 of high-level side
B7	High voltage I/O channel 7	Input-Output channel 7 of high-level side
B8	High voltage I/O channel 8	Input-Output channel 8 of high-level side
GND	Ground	Ground, 0 V

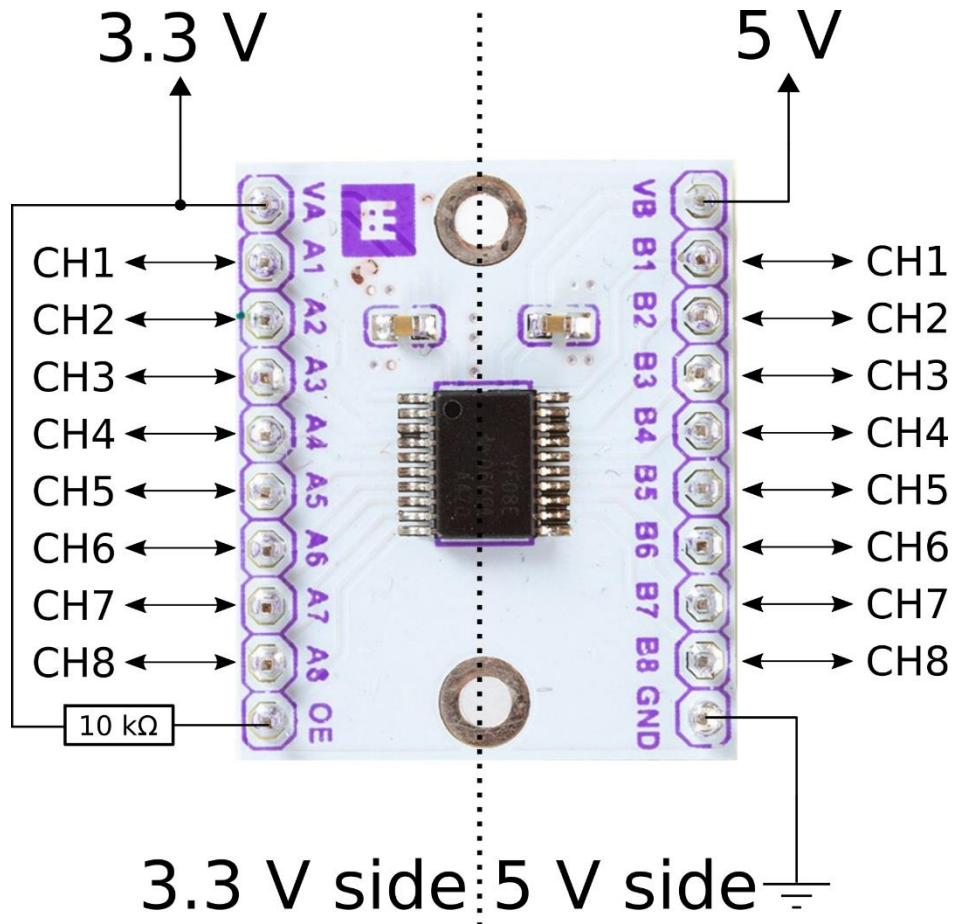



whadda.com



Modifications and typographical errors reserved - © Velleman Group nv. WPI474
Velleman Group NV, Legen Heirweg 33 - 9890 Gavere.