

K8019

ILLUSTRATED ASSEMBLY MANUAL H8019IP*1

PROXIMITY CARD READER WITH USB INTERFACE



@velleman RnD



Features

- Store up to 250 tags.
- With USB interface for config-management.
- Free tag management application for PC.
- Fully documented protocol, write your own application.
- Tags can also be entered using a 'mastercard'.
- Toggle or pulse NO/NC relay output.
- Adjustable pulse time: 1s to 4 min. approx.
- 3 status leds and buzzer.
- Two tags supplied (card-type).
- Works standalone.

Specifications

- EM4100 compatible.
- Relay contact: 3A/24VDC.
- Power supply: 12VDC or 5VDC (USB)*
- Power consumption: 100mA max.
- Dimensions: 69x80x47mm / 2.71x3.15x1.85"

Optional:

- ◇ Access card : HAA2866/TAG
- ◇ Access badge : HAA2866/TAG2

*Only for configuration and tag learning. Relay will not operate.

Search product

Search Product

Navigation

- Home page
- Products
- Sales outlets
- Support
- Publications
- Jobs
- About us

News

NEW PKE193 LED CURB

CubeAnimator software available for download here!!

Posted on 04-06-12

[Read more...](#)
velleman
 projects

 Velleman Projects
 All about the Velleman own
 developments: Kits, Modules,
 Instruments and Home Automation

 United Kingdom -
 English (UK)
 Change

Velleman Projects Newsletter

Are you an electronics enthusiastic or simply interested in our kits, mini-kits, modules and instruments?

Subscribe to our Newsletter and receive every month the latest news, new products & updates on Velleman Projects.

You will receive an e-mail. Click on the link in that e-mail to confirm your subscription.

Email:



Do you want to unsubscribe? Click on the 'unsubscribe' link in the footer of the last received newsletter from Velleman Projects.

- velleman.eu
- happower.eu
- perl.eu
- vellemanprojects.com
- uk - modules - instruments
- velbus.eu
- forum.velleman.eu

Advertisements

- DMC1
- DAC3
- A1
- KBDS5(N) / VH110(N)
- Android Application



Subscribing our newsletter?, visit www.vellemanprojects.eu

velleman
 projects

INSTRUMENTS
 velleman
 projects
 kit

 Support Forum (EN/FR)
 Velleman Projects

Login: Register

Search

Logout

Velleman Instruments with 3 other active topics

It is currently Fri Aug 14, 2014 6:50 pm

Board index

48 topics, 676 posts

	Topics	Posts	Last post
General			
Forum rules - Règles du forum	0	0	Fri Dec 04, 2008 04:06 pm Velleman MD
Help / FAQ / A-Z of acronyms	1	4	Thu Nov 01, 2012 11:22 pm Velleman MD
Forum Administration			
Velleman Software Forum Resources			
Moderator: Velleman Support			
Modules			
Velleman Home Automation	404	2072	Thu Sep 11, 2013 01:01 pm Dariusz MD
Simple solution for the new Vellebus Home Automation System (Simplified)			
Moderator: Velleman Support			
Kits (Substituting projects - Projects à modifier)			
General	176	428	Sat Sep 05, 2014 01:07 pm Velleman MD
Kit of the Month	0	0	
Audio & Hi-Fi Projects	607	3400	Fri Sep 14, 2012 6:32 pm Velleman MD
All audio related projects, amplifiers, active amplifiers			
Moderator: Velleman Support			
PC Related Projects	1438	6908	Thu Sep 11, 2013 04:04 pm Mark MD
The projects that are connected to the PC like software tools			
Moderator: Velleman Support			
Microcontroller Programmers - Expanding Projects	487	1740	Thu Sep 11, 2014 02:07 pm S&S192 MD
More like our own related PC programming, example kits			
Moderator: Velleman Support			
Tools and Devices	214	856	Fri Sep 07, 2013 6:40 pm Velleman MD
All about our own related projects from regular checks to programmable things			
Moderator: Velleman Support			
Vellebus Projects	634	2363	Fri Sep 14, 2012 12:00 pm Velleman MD
Moderator: Velleman Support			

**View
 Forum**

Participate our Velleman Projects Forum



Velleman N.V.

Legen Heirweg 33

9890 Gavere

(België)

assembly hints

1. Assembly (Skipping this can lead to troubles !)

Ok, so we have your attention. These hints will help you to make this project successful. Read them carefully.

1.1 Make sure you have the right tools:

- A good quality soldering iron (25-40W) with a small tip.
- Wipe it often on a wet sponge or cloth, to keep it clean; then apply solder to the tip, to give it a wet look. This is called 'thinning' and will protect the tip, and enables you to make good connections. When solder rolls off the tip, it needs cleaning.
- Thin raisin-core solder. Do not use any flux or grease.
- A diagonal cutter to trim excess leads. To avoid injury when cutting excess leads, hold the lead so they cannot fly towards the eyes.
- Needle nose pliers, for bending leads, or to hold components in place.
- Small blade and Phillips screwdrivers. A basic range is fine.

☞ For some projects, a basic multi-meter is required, or might be handy.



1.2 Assembly Hints :

- Make sure the skill level matches your experience, to avoid disappointments.
- Follow the instructions carefully. Read and understand the entire step before you perform each operation.
- Perform the assembly in the correct order as stated in this manual.
- Position all parts on the PCB (Printed Circuit Board) as shown on the drawings.
- Values on the circuit diagram are subject to changes, the values in this assembly guide are correct*.
- Use the check-boxes to mark your progress.
- Please read the included information on safety and customer service.

* Typographical inaccuracies excluded. Always look for possible last minute manual updates, indicated as 'NOTE' on a separate leaflet.

1.3 Soldering Hints :

1. Mount the component against the PCB surface and carefully solder the leads. →



2. Make sure the solder joints are cone-shaped and shiny. →

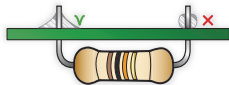

3. Trim excess leads as close as possible to the solder joint. →



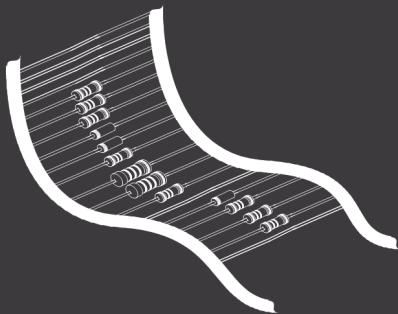

REMOVE THEM FROM THE TAPE ONE AT A TIME !

Included in
this kit

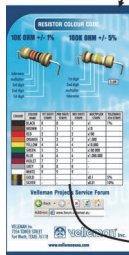

2. RESISTOR

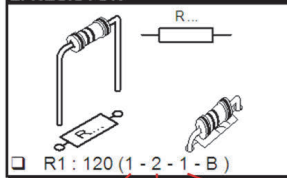

COLOUR	COLOUR NAME	1ST DIGIT/ STRIPE	2ND DIGIT/ STRIPE	3RD DIGIT/ STRIPE	MULTIPLIER STRIPE	TOLE 4TH!
	BLACK	0	0	0	x1	1%
	BROWN	1	1	1	x10	
	RED	2	2	2	x100	
	ORANGE	3	3	3	x1.000	
	YELLOW	4	4	4	x10.000	
	GREEN	5	5	5	x100.000	
	BLUE	6	6	6	x1.000.000	

DO NOT BLINDLY FOLLOW THE ORDER OF THE COMPONENTS ONTO THE TAPE. ALWAYS CHECK THEIR VALUE ON THE PARTS LIST!

I CONSTRUCTION

Component PCB

1 Jumper wire

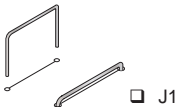

2 Diodes

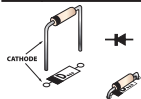

Watch the polarity!

- D1: 1N4148
- D2: 1N4148
- D3: 1N4148
- D4: 1N4148
- D5: 1N4148

3 Zenerdiodes

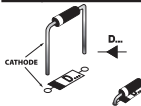

Watch the polarity!

- D6: 1N4007
- D7: 1N4007

4 Resistors

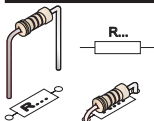

- R1: 470 (4 - 7 - 1 - B)
- R2: 470 (4 - 7 - 1 - B)
- R3: 470 (4 - 7 - 1 - B)
- R4: 100K (1 - 0 - 4 - B)
- R5: 100K (1 - 0 - 4 - B)
- R6: 10K (1 - 0 - 3 - B)
- R7: 10K (1 - 0 - 3 - B)
- R8: 10K (1 - 0 - 3 - B)
- R9: 220K (2 - 2 - 4 - B)
- R10: 220K (2 - 2 - 4 - B)
- R11: 4K7 (4 - 7 - 2 - B)
- R12: 4K7 (4 - 7 - 2 - B)
- R13: 1K (1 - 0 - 2 - B)
- R14: 39K (3 - 9 - 3 - B)
- R15: 1M (1 - 0 - 5 - B)
- R16: 10 (1 - 0 - 0 - B - 9)*
- R17: 330 (3 - 3 - 1 - B)
- R18: 330 (3 - 3 - 1 - B)
- R19: 1K (1 - 0 - 2 - B)
- R20: 560 (5 - 6 - 1 - B)
- R21: 1K2 (1 - 2 - 2 - B)
- R22: 10K (1 - 0 - 3 - B)
- R23: 10 (1 - 0 - 0 - B - 9)*

* Metallfilm resistor

5 Ceramic Capacitors



- C7 : 100nF (104)
- C8 : 100nF (104)
- C9 : 100nF (104)
- C10 : 100nF (104)
- C11 : 100nF (104)
- C20 : 100nF (104)

6 IC sockets

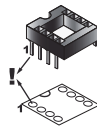

IC1: 8p

Watch the position of the notch!

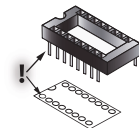

IC1: 16p

7 Ceramic Capacitors

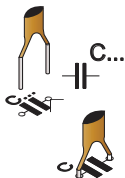

- C1: 10nF (103)
- C2: 10nF (103)
- C3: 10nF (103)
- C4: 4.7nF (472)
- C5: 4.7nF (472)
- C6: 4.7nF (472)
- C12: 100pF (101)
- C13: 100pF (101)
- C14: 470pF (471)
- C16: 22pF (22)
- C17: 22pF (22)

- C18: 470nF (474)

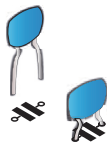

8 Transistors

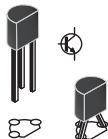

- T1: BC547B
- T2: BC547B
- T3: BC547B
- T4: BC557

9 Buzzer

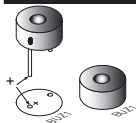

Watch the polarity!

- BUZ1

10 Terminal block

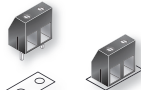

- SK5: 2p (power)

11 USB connector

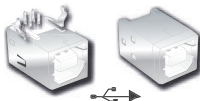

- SK3

12 Board to wire 'male'

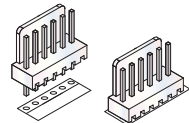

- SK1: 6p

13 Electrolytic capacitors



Watch the polarity!

- C15: 4,7 μ F
- C19: 100 μ F

14 Terminal block

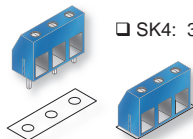

- SK4: 3p (Relay out)

15 Quartz crystal

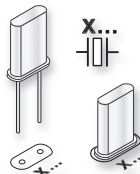

- X1: 12MHz

16 Voltage regulator



□ VR1: UA7805

17 Relay



□ RY1: VR15121C

18 IC's



Watch the position
of the notch!



□ IC1: LM358

□ IC2: VK8019

(programmed PIC18F14K50-I/P)



RFID reader PCB

1 Led's. Watch the polarity!

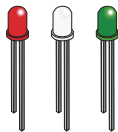

- LD1 (red)
- LD2 (blue)
- LD3 (green)

A

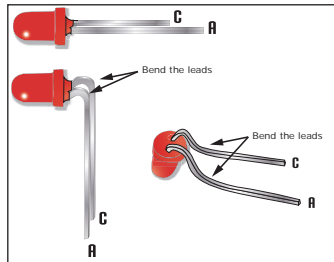

B

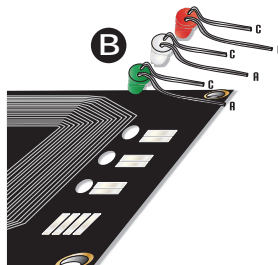

C

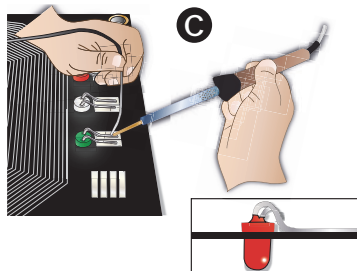

2 Board to wire (Female)

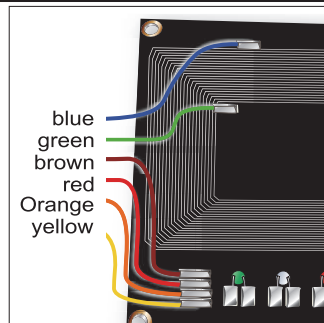
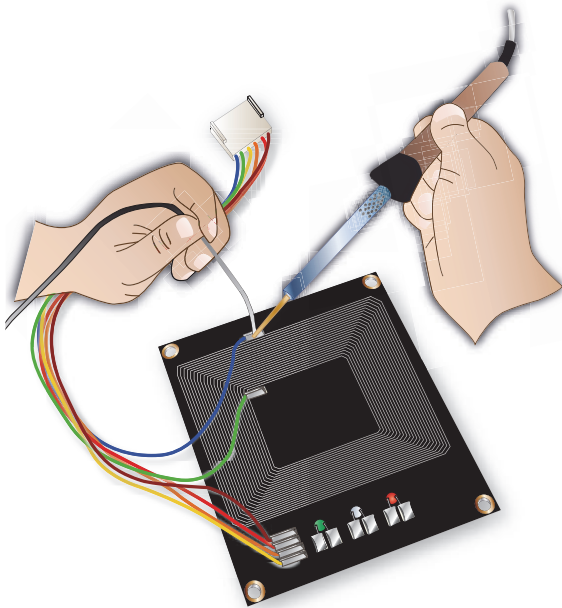

Connect to
main board

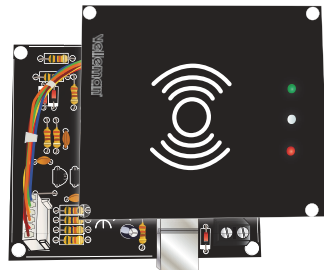

II ASSEMBLY

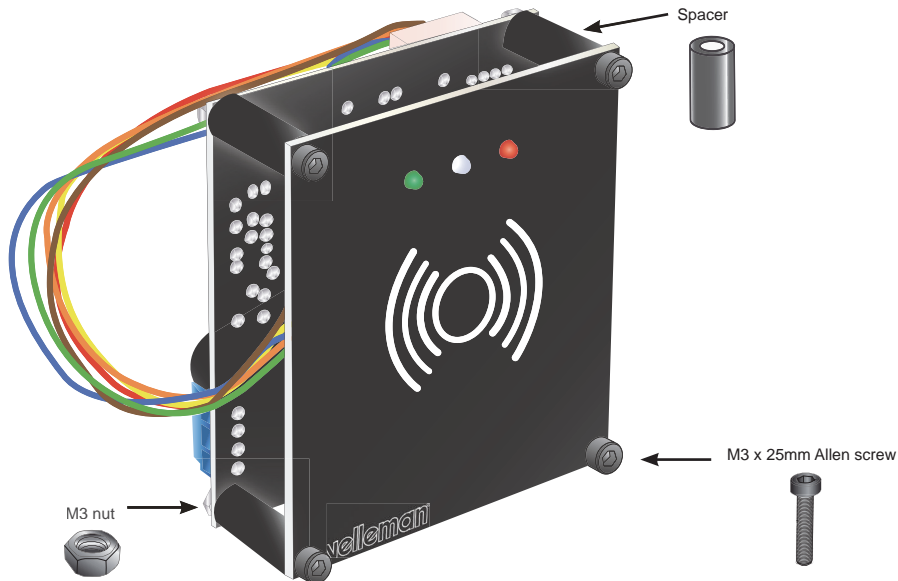

III HOOK-UP EXAMPLE

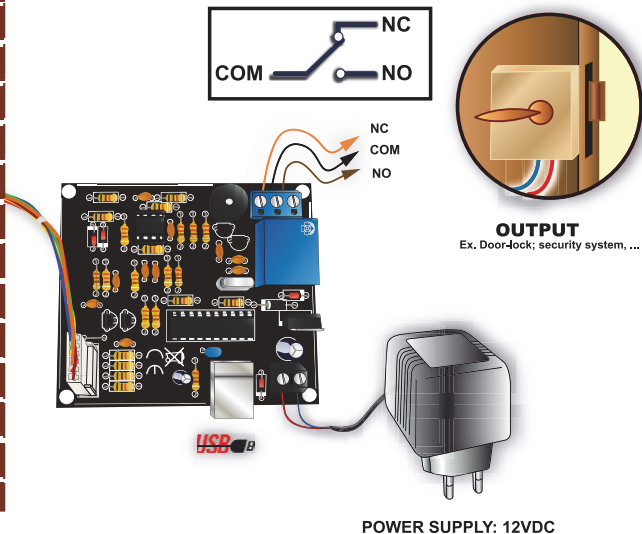

IV. SOFTWARE INSTALLATION

Remark: Software installation is not mandatory, since the first card that is learned puts the unit into learnmode. Once in learnmode, you can learn more cards. See page 15



Step 1: Download the software on our website.

Step 2: open the file en select the software.

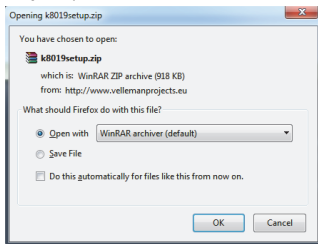

Step 3: Select "next" to begin the installation.



Step 4: Select the destination on your PC.

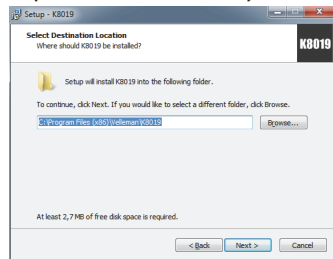

Step 5: Select the "Start folder" menu where program shortcuts should be placed.

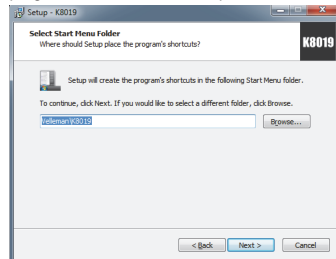

Step 6: Select additional tasks you would like to be performed.

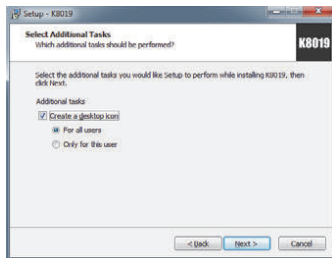

Step 7: Select "install" for installing the software.

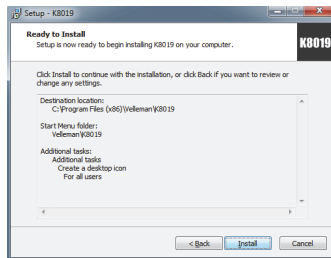

Step 8 : Click "finish" to exit setup.



V. DRIVER INSTALLATION

Connect the USB connector of the K8019 to your PC using an USB cable.

With the first connection, you should install the USB driver onto the PC first.

You can download the manual for installing the driver on our website.

VI. INDICATIONS

A. Leds

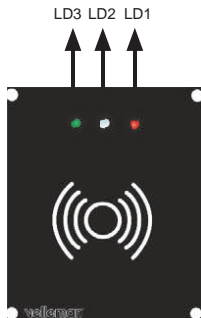

The card reader has three colored leds: green, blue and red.

LED	STATUS	
LD1	ON	Relay off
LD2	ON	power on
	Blinking	learning mode enabled
LD3	ON	Relay energized

B. Sound



••• enter / leave learn mode



--- invalid card



• Valid card / card stored (learning mode)

VII. SET-UP

Relay

When a valid card is presented the relay is energized.

The relay has three configurations (the configuration is done via the PC):

- **Toggle:** swipe= ON, swipe= OFF.
- **Momentary:** ON while card is present.
- **Timer/delayed:** swipe= ON for n seconds.

Learning mode

One card can be the master card, which is used to toggle learning mode.

If an invalid card is swiped while in learning mode, the card is added to the card reader's memory.

If the card reader contains 0 cards, then the next card swiped will automatically trigger learning mode and the card will be stored as the master card. Learning mode will automatically timeout after 30 seconds. If a card is swiped within this period, the timeout is reset to another 30 seconds.

- ⌚ *During learning mode, the relay remains OFF.*
- ⌚ *If you do not get a beep when presenting a card in learning mode, then the database is full (250 card limit).*
- ⌚ *A card can not be removed, this is only possible via the PC application.*

Validating a card

An RFID tag consists of five bytes. Only the last four bytes are used for validation. These last four bytes represent the number printed on the front of the RFID card. The first byte is considered to be the manufacturer's id and thus is ignored.

VIII. HOW DOES AN RFID WORK?

An RFID tag sleeps in normal mode: it does not perform any activities and does not use any power. This will change as soon as the tag moves through the reader's field. An RFID reader emits radio waves at a frequency similar to those of the tag. The tag antenna retrieves enough energy from these waves so as to exit the tag from the sleep mode and to power the microchip.

The tag's microchip initiates a wireless communication with the reader (comparable to what happens with a classic network) and receives a command. The chip will execute the command, resulting in a data transfer through the tag's antenna. In case of the passive tag in the example, the data consists of the unique serial number of the tag in binary format (1's and 0's) emitted as radio waves.

The antenna will pick up the data emission and sends it through a cable and in the form of electrical signals to the reader's control module. The module will in turn decode the radio signals and retrieve the binary data. The reader now has the tag's ID in digital format, which can be processed or printed immediately. This data will mostly be completed with additional data (e.g. time and location) and quickly forwarded to a processing unit or information system.

Important: The tag's chip has a unique number, i.e. the chip's serial number allocated during its manufacturing.

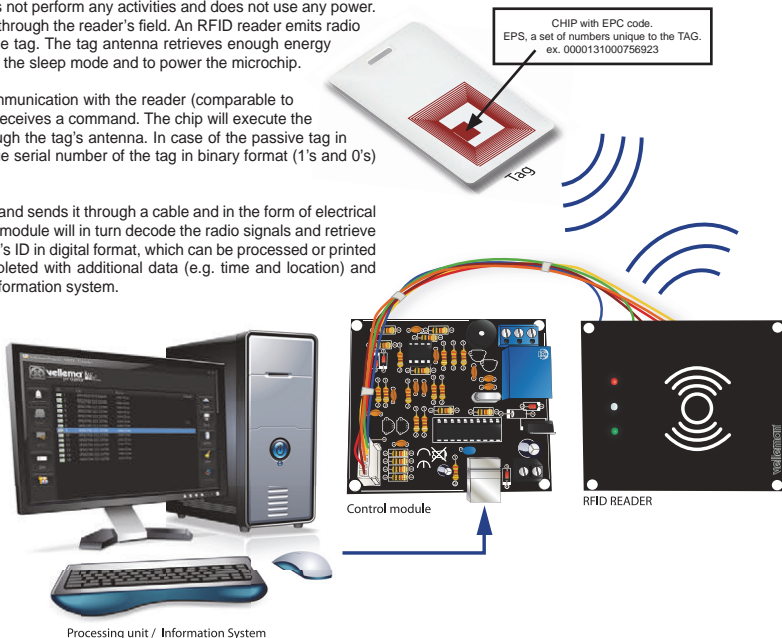

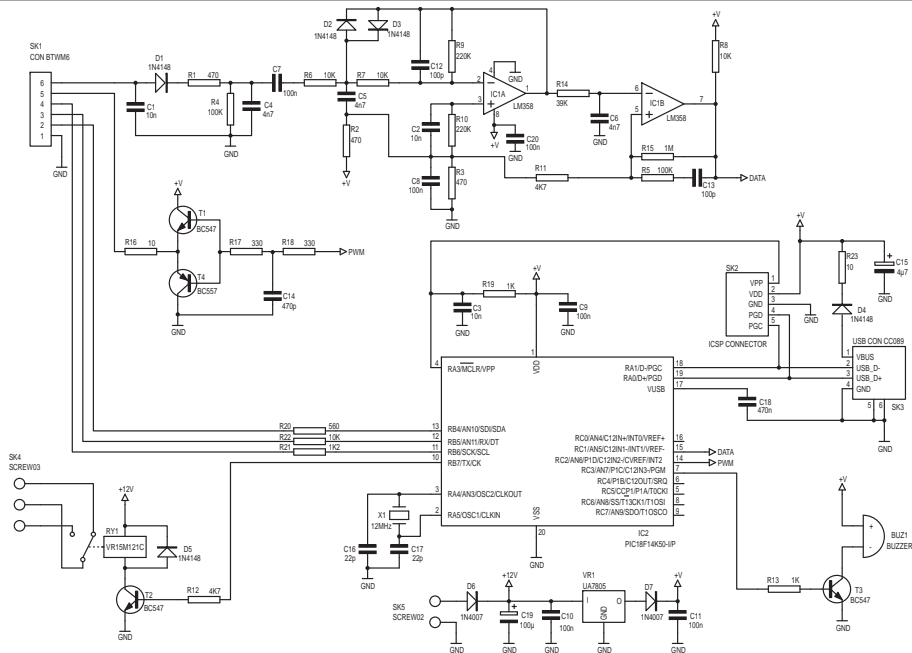



velleman

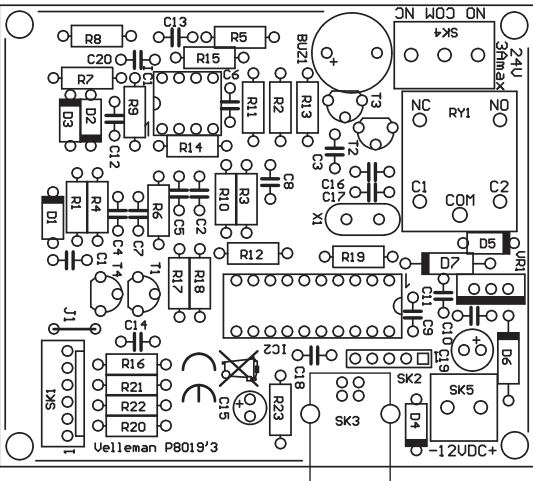

Leds and how to use them

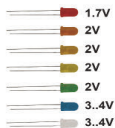

Leds feature a specific voltage drop, depending on type and colour. Check the datasheet for exact voltage drop and rated current!

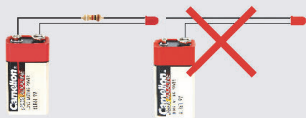
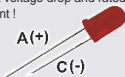

Never connect leds in parallel

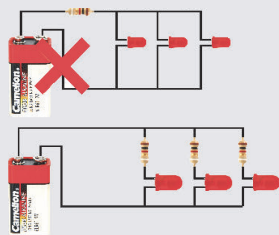

How to Calculate the series resistor:

Example: operate a red led (1.7V) on a 9Vdc source.

Required led current for full brightness: 5mA (this can be found in the datasheet of the led)

$$\frac{\text{Supply voltage (V)} - \text{led voltage (V)}}{\text{required current (A)}} = \text{series resistance (ohms)}$$



$$\frac{9V - 1.7V}{0.005A} = 1460 \text{ ohm}$$

closest value :
use a 1k5 resistor

Required resistor power handling=
voltage over resistor x current passed trough resistor



$$(9V - 1.7V) \times 0.005A = 0.036W$$

a standard 1/4W resistor
will do the job

LEDs in series:

Example: 3 x red led (1.7V) on 9V battery
Required led current for full brightness: 5mA
(this can be found in the datasheet of the led)

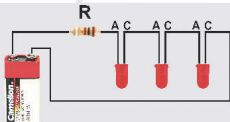

$$\frac{\text{Supply voltage (V)} - (\text{number of leds} \times \text{led voltage (V)})}{\text{required current (A)}} = \text{series resistance (ohms)}$$



$$\frac{9V - (3 \times 1.7V)}{0.005A} = 780 \text{ ohm}$$

use an
820 ohm resistor

open collector outputs

An open collector output can be compared to a switch which switches to ground when operated

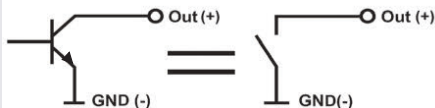

Example: How to switch an LED by means of an open collector output

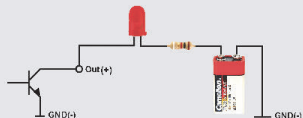



The new Velleman Projects catalogue is now available. Download your copy here:

www.vellemanprojects.eu

 @velleman_RnD



Modifications and typographical errors reserved - © Velleman nv. H8019IP1 (rev.1)
Velleman NV, Legen Heirweg 33 - 9890 Gavere.